

PowerMount Series Assembly Instructions

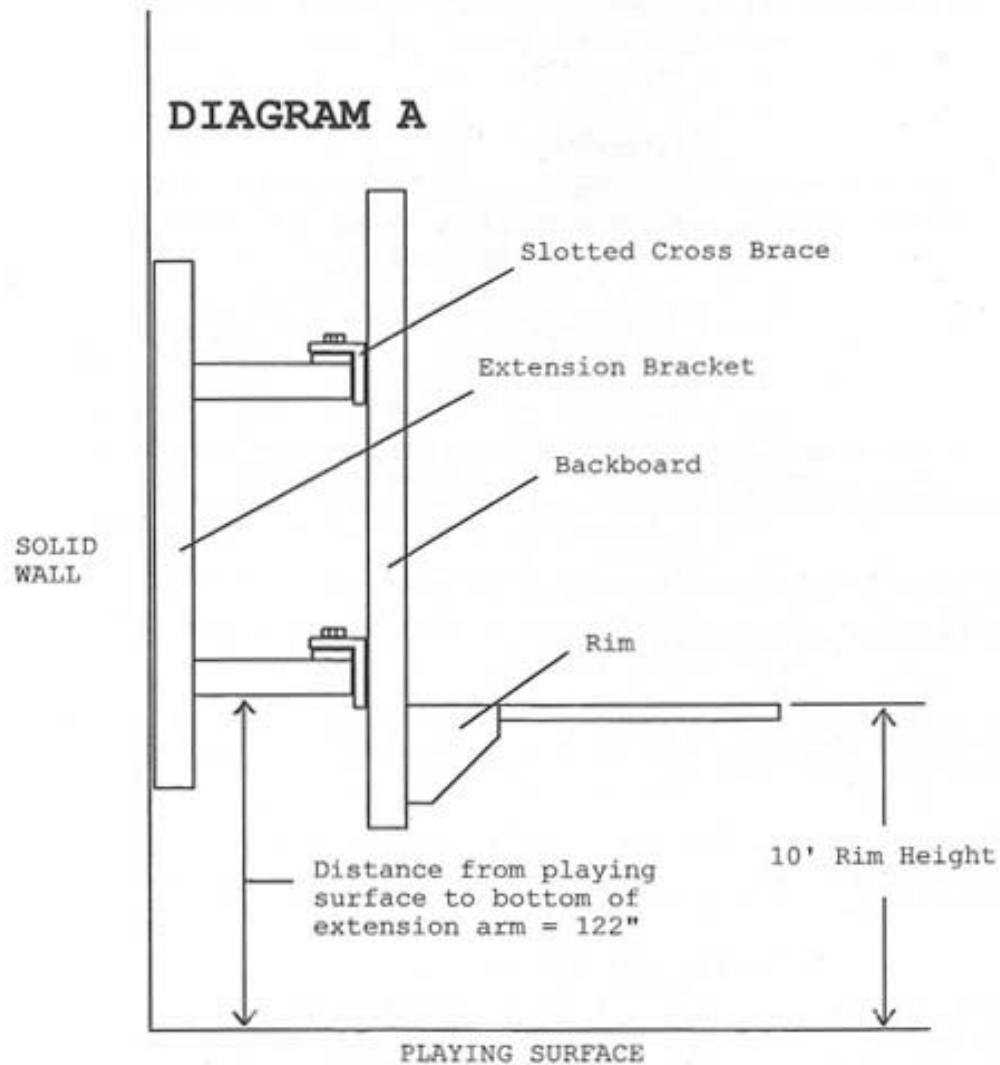

Bill of Materials

| | | |
|------------------------------------|--------------------------------|---------------------------------|
| A (2) Extension Bracket | J (8) 1/2" Locknut | S (1) Rim Height Sticker |
| B (2) Slotted Cross Brace | K (4) 5/8" Anchor Bolt | T (1) Rim Height Indicator |
| C (16) 3/8" x 1 1/2" Carriage Bolt | L (12) 5/8" Hex Nut | U (4) 5/8" Lockwasher |
| D (8) 3/8" x 1 1/4" Hex Bolt | M (1) Anchor Footing Template | V (1) Anti-Seize Lubricant |
| E (16) 3/8" Flatwasher | N (4) Anchor Footing Rebar | W (2) Pivot Stop Caps |
| F (16) 3/8" Lockwasher | O (8) 5/16" x 1" Machine Screw | X (2) Base Cover Screws |
| G (16) 3/8" Hex Nut | P (8) 5/16" Flatwasher | Y (2) Plastic Base Cover (Half) |
| H (5) 1/2" x 10" Hex Bolt | Q (8) 5/16" Lockwasher | |
| I (1) 1/2" x 11" Hex Bolt | R (8) 5/16" Hex Nut | |

CAUTION!!!

Wall mount structures require an acceptable wall mounting surface. Brick, block, or poured concrete walls are superior. It is inadvisable to mount structures to walls with wood or steel studs unless additional work approved by an engineer is done to provide additional support. First Team does not provide wall anchors with any structure. The purchaser assumes liability for the installation of any wall mounting structure. Consult a professional architect, engineer, or contractor to determine safe methods of installation to your facility's wall construction.

Note!!!

All assembly materials are supplied except hardware to attach the structure to the customer's wall. Attachment method and type of anchor used are the responsibility of the installer.

1. Inspect all contents prior to installation.

Read all instructions before proceeding.

2. In order to protect your unit against freight damage, your PowerMount Extension Brackets are shipped to you "fastened" together using (2) 3/8"x 1 1/4" Hex bolts, flatwashers, lockwashers and hex nuts. Remove these bolts to separate the Extension Brackets before proceeding. DO NOT discard bolts, they may be used later during installation procedure.

3. Using diagram B, determine the appropriate distance (Distance A) between the Extension Brackets. This distance will be determined based on the most convenient location according to your wall structure.

4. Secure both Slotted Cross Braces to the Extension Brackets as shown in diagram B using (8) 3/8" Carriage Bolts, Flatwashers, Lockwashers and Hex Nuts. Make sure to attach Slotted Cross Braces with the "double" slotted side facing out as shown in Diagram B.

5. Attach entire assembly to wall as shown in diagram A. 1/2" holes are provided for attachment, however no anchoring hardware is provided. It is the responsibility of the installer to select the correct anchoring hardware for your particular installation. The distance from the playing surface to the underside of the Extension Arm (see diagram A) should be 122" +/- 1/4".

NOTE: Anchor each Extension Bracket in no less than four places. If the wall is masonry (Brick over block), block, or poured concrete and it's possible to drill through the wall and you have access to the other side of the wall it is strongly recommended that the installer bolts through the wall using 1/2" bolts.

WARNING!!!

SEVERE INJURY TO PLAYERS OR FANS MAY RESULT FROM FAILURE TO SELECT A PROPER ANCHORING SYSTEM GIVEN THE CONSTRUCTION AND CONDITION OF THE WALL OR THE IMPROPER USE OF THE PROPER ANCHORING SYSTEM.

6. Attach backboard to face of Slotted Cross Braces as shown in diagram A. Use attachment hardware provided with the backboard. If no attachment hardware was provided with your backboard, try using the leftover 3/8" hardware provided with this structure.

7. Attach rim and hang net. Make sure all hardware is snug before playing on unit. NOTE: Cross Braces are "double" slotted to allow adjustment for rim height. If rim is not 10', try attaching the backboard to the alternate mounting slot.

ATTENTION!!!

WALL MOUNTED STRUCTURES SHOULD BE CHECKED YEARLY FOR LOOSE BOLTS OR ANCHORS!

POWERMOUNT DIAGRAM B

