

Slam Series Assembly Instructions

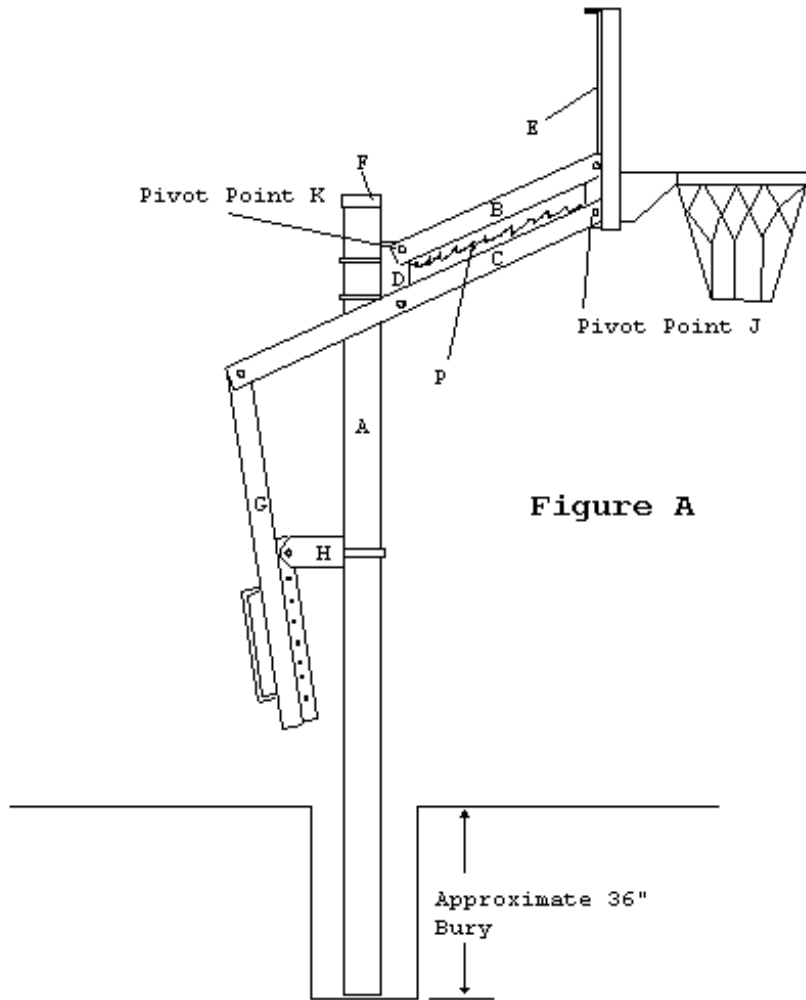

Figure A

Bill of Materials

| | |
|--------------------------------|-------------------------------|
| A (1) Vertical Post | I (1) ½" x 8" Adjustment Pin |
| B (2) Short Extension Arm | J (5) ½" x 11" Hex Bolt |
| C (2) Long Extension Arm | K (5) ½" Locknut |
| D (1) Extension Arm Support | L (3) ½" x 4" U-Bolt |
| E (1) I-Frame B-board Mounting | M (6) ½" Lockwasher |
| F (1) 4" Square Post Cap | N (6) ½" Hex Nut |
| G (1) Adjustment Handle | O (8) ½" Nylon Flatwasher |
| | P (2) Lift Spring |
| H (1) Pin Adjustment Bracket | Q (4) 5/16"x 1" Machine Screw |
| | R (4) 5/16" Flatwasher |
| | S (4) 5/16" Lockwasher |
| | T (4) 5/16" Hex Nut |

NOTE: Immediately unpack all components and cross check against bill of materials.

1. Locate and dig a 12" minimum diameter x 36" deep hole.
2. Fill hole with wet premixed concrete, insert vertical pole leaving 108" above desired playing surface. Vibrate to settle concrete.
3. Make sure post is straight and plumb. Brace while drying if necessary. Allow 24 hours minimum drying time before continuing assembly. Place 4" square post cap on top of pole.
4. Using ½" x 4" U-Bolts, lockwashers and nuts attach the extension arm support to the vertical pole either at desired rim height or at ground level. If you choose to bolt extension arm support up high first, the bottom of the extension arm support should be bolted 93 ½" up from playing surface.
5. Loosely attach all four extension arms to the extension arm support using ½"x 11" hex bolts, ½" nylon flatwashers and hex nuts. (The short extension arms go on top and the nylon flatwashers go between the extension arms and the extension arm support to prevent paint rubbing)
6. Using the 5/16" hardware provided with your backboard, bolt the I-Frame Backboard Mounting (as shown in Figure B) to the center four holes located at the top of your backboard. Remove and discard the plastic shipping block located at the backboard joint
7. READ THIS ENTIRE STEP BEFORE PROCEEDING: Attach desired rim loosely with the hardware provided in the rim box. Rim should bolt through backboard and into I-Frame. ATTENTION: If your backboard is ACRYLIC (FT210, FT215, or FT220) be sure to sandwich one black rubber gasket (provided with backboard) between the backplate of the rim and the face of the backboard and the other gasket between the Backboard I-Frame support and the backside of the backboard when attaching rim. Trim gaskets if necessary. ATTENTION: If your backboard is TEMPERED GLASS (FT216 or FT221) your backboard should have (4) aluminum core grommets inserted into the glass where the rim bolts through. If they are not in the backboard, look in the box, they may have fallen out during shipping. If you cannot locate all four aluminum cores, DO NOT PROCEED WITH ASSEMBLY, call First Team immediately, 1-888-884-6677.
8. Using the 5/16" hardware provided in the bolt bag, attach the I-Frame bottom angle to the bottom four holes in the backboard aluminum frame as shown in Figure B.
9. Attach the Backboard/I-Frame/Rim assembly to the lower set of arms using a ½"x 11" hex bolt and locknut. Use one nylon flatwasher between both extension arms and the I-Frame backboard support.
10. Attach upper set of arms to the Backboard/I-Frame/Rim assembly using a ½" x 11" hex bolt and locknut. Use one nylon flatwasher between both extension arms and the I-Frame backboard support.
11. Tighten all bolts except where extension arm support mounts to the vertical pole. Make sure rim is square with the backboard, etc.
12. If you are working at ground level, slide the entire assembly up the vertical post until the bottom of the extension arm support is 93 ½" above the playing surface. Make sure entire project is level and square, tighten U-Bolts now. IMPORTANT! Do not overtighten U-Bolts, this can cause damage to the extension arm support. Just tighten U-Bolts until they are snug.
13. Using a ½" x 4" U-Bolt, lockwashers and nuts, attach the Pin Adjustment Bracket to the back side of the vertical post so the bottom of the bracket is 47 ¼" above the playing surface, tighten it now. Do not overtighten U-Bolts.

14. At this time it is necessary to work on the pin adjustment bracket so the 8" adjustment pin glides freely in and out. Because the pin adjustment bracket is designed with a "net fit" on the adjustment pin it is important to lubricate the pin, (we suggest vaseline) this will allow free movement through the tubes. After the pin has been lubricated, try pushing it all the way through the tubes on the pin bracket. If this is still difficult the bracket ears may have become misaligned while tightening the U-Bolt. You can correct this by using a crescent wrench to slightly bend ears back to their original position allowing the pin to glide freely in and out. Lubricate pin every six months.

15. Bolt on the Adjustment Handle to the lower set of arms using a 1/2" x 11" hex bolt and nut.

16. With some help, pull down on the adjustment handle and pin the unit at ten feet using the 1/2" x 8" adjustment pin. (You will pin it in the top hole on the adjustment handle)

17. Attach (2) lift springs from pivot point J to pivot point K as shown in Figure A. You may find it helpful to loop a rope over pivot point K and attach it to one end of the spring. Then with the spring already attached to pivot point J pull down on the rope, extending the spring until it hooks itself over pivot point K.

18. Make sure all nuts are tight and project is still level and square.

Figure B

5/16" Attachment Hardware

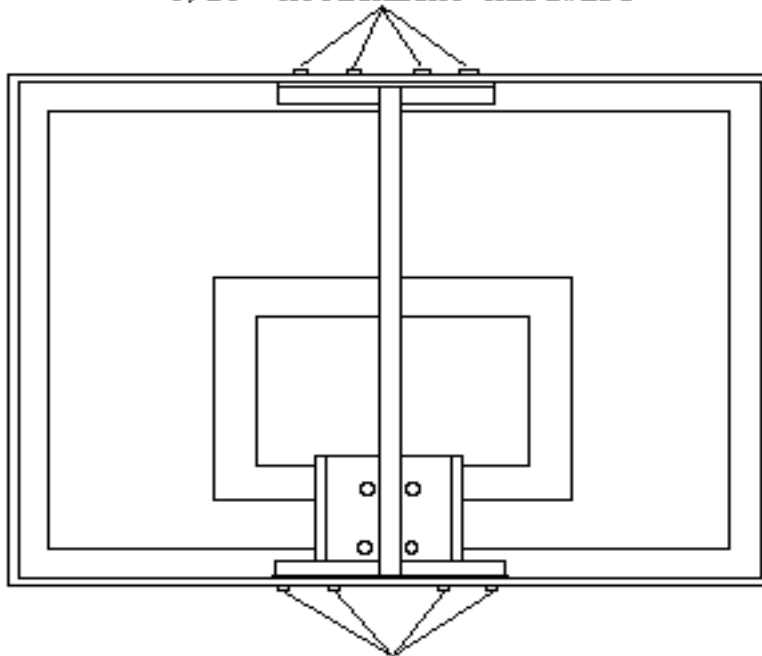

5/16" Attachment Hardware